

VPP series are low running mixers specially designed for the mixing of quite viscous fluids. They are suitable for medium volume tanks up to 4 - 5 m<sup>3</sup>. Thanks to their life greased reducer gear it is a friendly maintenance machine just to connect and run. The S type axial profile propeller is designed to reach a balanced pumping flow/power absorption ratio. The propeller can be easily adjusted along the shaft if necessary, or it can be equipped with two or more propellers.

### Main features:

- For tanks 0,5 – 5 m<sup>3</sup>.
- Motor power: 0,18 kW to 2,2 kW.
- Running speed 300 rpm (other spee available).
- 3 blades type S axial profile propeller diameter 200–400 mm.
- Shaft length up to 1500 mm.
- Shaft and propeller AISI 316, or polyethylene coated.

### Optional extras:

- PVC or AISI 316 flange with oil seal.
- Rubber coated shaft + propeller.
- Food industry execution, polished.
- ATEX motors.
- DIN or ANSI flanges.
- Special executions.

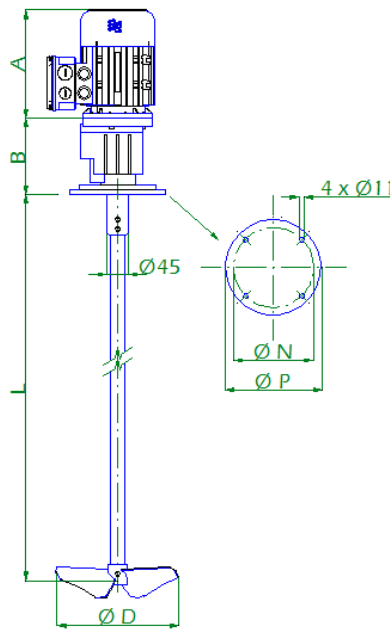

| Model           | Power kW | Speed rpm | A   | B   | D   | L max. | N   | P   | Weight Kg | Vol. m <sup>3</sup> |
|-----------------|----------|-----------|-----|-----|-----|--------|-----|-----|-----------|---------------------|
| VPP3-01 03 B 01 | 0,18     | 310       | 187 | 173 | 200 | 1500   | 165 | 200 | 22        | 0,5                 |
| VPP3-03 03 B 25 | 0,37     | 305       | 207 | 173 | 250 | 1500   | 165 | 200 | 24        | 0,5 – 1             |
| VPP3-05 03 B 02 | 0,75     | 309       | 225 | 179 | 300 | 1500   | 210 | 250 | 31        | 1 – 2               |
| VPP3-06 03 B 03 | 1,1      | 309       | 274 | 208 | 350 | 1500   | 210 | 250 | 35        | 2 – 3               |
| VPP3-07 03 B 04 | 1,5      | 289       | 248 | 208 | 400 | 1500   | 210 | 250 | 40        | 3 – 4               |
| VPP3-08 03 B 04 | 2,2      | 289       | 309 | 208 | 400 | 1500   | 210 | 250 | 45        | 4 – 5               |

Dimensions in [mm].

(\* ) Tank volumes only for guidance.

Due to our policy of constant improvement, shown values can be changed.

Tineo, 17 ■ 28031 Madrid (Spain) ■ Tel: + 34 91 170.19.24 ■ sales@fluidmix.es